

Distribution and reproduction of this document, as well as Use or communication of the contents thereof, are forbidden unless expressly authorized. All rights reserved

Weitergabe und Vervielfältigung dieser Unterlage, sowie Verwertung und Mitteilung ihres Inhalts nicht gestattet, soweit nicht ausdrücklich zugestanden. Alle Rechte vorbehalten

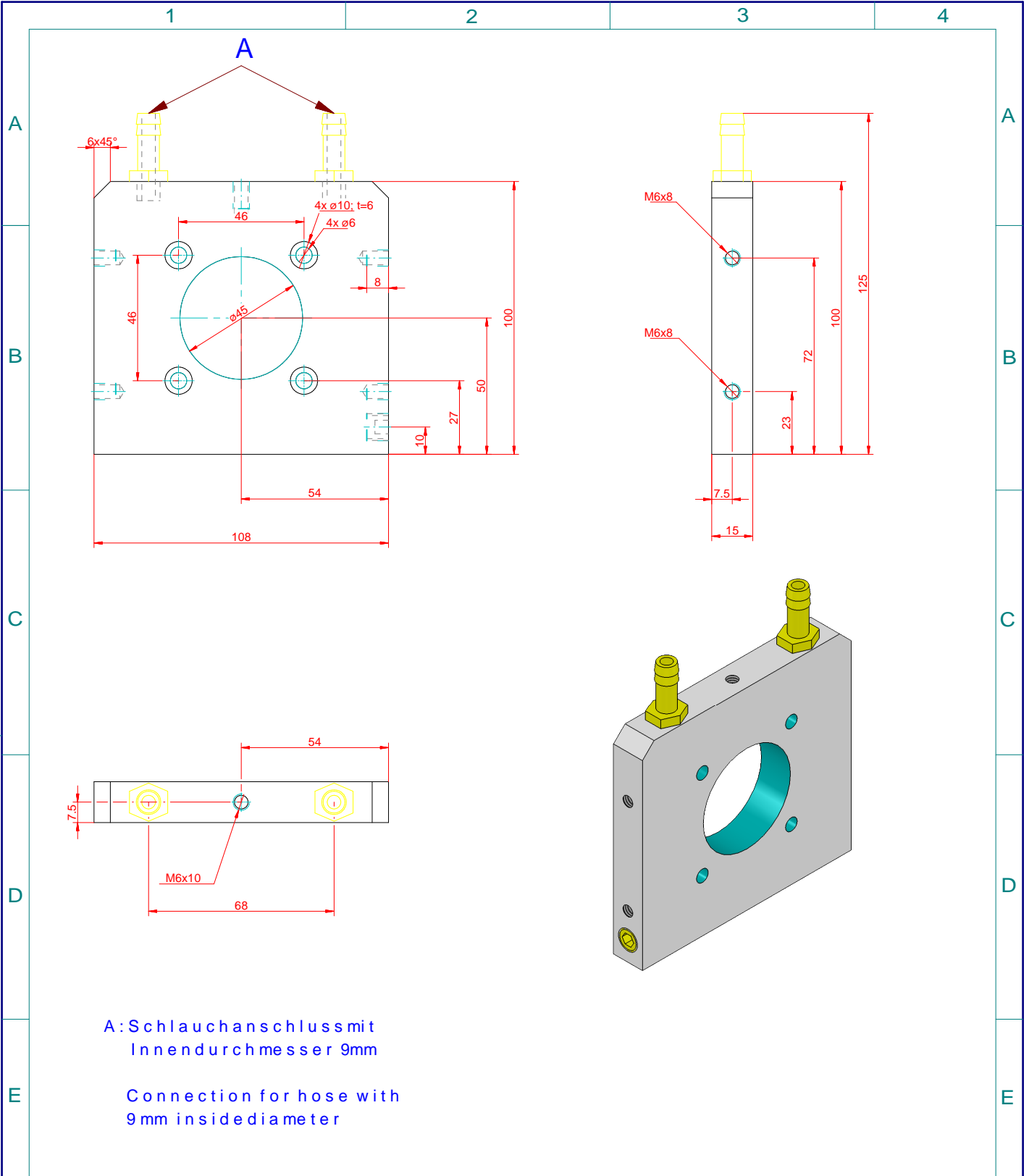

A: Schlauchanschluss mit Innendurchmesser 9mm

Connection for hose with 9mm inside diameter

		Maße in mm Dimensions in millimeters	Zul. Abw. f. Maße ohne Toleranzang. General tolerances	Fertigzustand finished condition	Maßstab Scale	Menge Quantity
			DIN ISO 2768 T1 m		1 : 2	
				Datum Date	Rohstoff/Raw material Aluminium / Messing 0,23Kg	
				Name Name	Rohteil-Nr./Raw piece No.	
					Werkzeug-Nr./Tool No.	
					Benennung/Designation	
					Wasser Kühlplatte Water cooled Front plate KG20-00	
					Sachnummer/Part-No.	
					ZN0088	
					Blatt Sheet	
					1	
					von of	
					1	
					Ursprung Source	
					MegaCAD	
					Dateiname Filename	
					ZN008801_KÜHlgehäuse_KG...pr	
					Ausg. Issue	
					Anderung Modification	
					Datum Date	
					20.08.15	
					Name Name	
					Ouh	
					Dateiname Filename	
					30.04.15	
					Name Name	
					Bu	

